

Operating Principles

The **Model 425-D Discrete Interval Sampler** allows samples to be taken from distinct levels in a well, borehole, or surface water body, typically from submerged depths as much as 1000 m (3200 ft). Deeper applications may be possible – please contact Solinst to determine the suitability of your application. Weights are added to the Discrete Interval Sampler before lowering to overcome buoyancy at greater depths.

The Discrete Interval Sampler operates on the basic principles of hydraulics. Once the Sampler reaches the desired sampling depth, it is pressurized. The pressure acts on the top of the internal piston (large surface area) overcoming the hydrostatic pressure acting on the bottom of the piston (small surface area) pushing the Sample Release Valve open, allowing sample water to fill the Sampler body. As the Piston assembly moves to open the Sample Release Valve, it also moves the Pressure Retainer away from a small o-ring sealed opening in the bottom of the Pressure Chamber, allowing the air to vent through the Vyon Filter on the exterior of the Sampler, while the Sampler fills with water.

After the sample is collected, the pressure is released from the Sampler, causing the Piston Rod to retract, sealing the Sample Release Valve and vent hole. The sealed Sampler is then retrieved to surface, maintaining chemical stability of the sample. At surface, the sample is collected by reapplying pressure to the Discrete Interval Sampler to open the Sample Release Valve.

- To connect the first weight, unscrew the Top Platen from the Top Retainer. Screw the weight into the Top Retainer until tight. Continue to add weights as required. Screw the Top Platen into the top of the last weight and tighten.



- Push tubing insert into the tubing. The compression fitting nuts may have to be loosened before the tubing is inserted. Tighten the nut 1-1/4 turns past finger tight for a proper seal. Note: Be careful not to lose the two pieces of the ferrule if loosening or removing the nut from the compression fitting. Re-tightening a ferrule assembly is 1/4 turn with wrench.

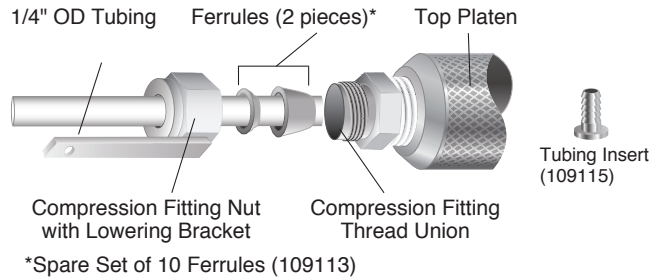

Sampling Pressure & Weight Requirements					
No. of Weights	Submerged Depth (Meters)	Sampling Pressure (kPa)	Submerged Depth (Feet)	Sampling Pressure	
				psi	Bar
0	50	345	160	50	3.45
0	100	345	320	50	3.45
1	200	345	640	50	3.45
2	300	520	960	75	5.17
3	400	690	1280	100	6.90
4	500	860	1600	125	8.62
5	600	1030	1920	150	10.34
6	700	1200	2250	175	12.07
9	1000	1380	3200	200	13.88

Notes:

- A single weight has a mass of 2 kg. Add 1 weight for every 100 m (300 ft) of submerged Sampler depth, after the first 100 m (300 ft).
- The 1.66" OD x 2 ft Discrete Interval Sampler weighs 3.7 kg (8.2 lbs).
- Sampling Pressure is the pressure required to open the Sample Release Valve.
- The discrete Interval Sampler holds 420 mL.

Sampling with the Discrete Interval Sampler

Notes:

- A safety support line should always be used to lower the Sampler.
- 425-D operates differently (in the opposite way) to our standard 425 Discrete Interval Sampler, please review instructions carefully.

- Before using the Discrete Interval Sampler, determine the desired submerged sampling depth.
- Based on the chart, determine the number of weights required for your submerged sampling depth. You may not need one.

- Remove Sample Screen and Plug. Use a standard screwdriver to tighten the Sample Release Valve into the bottom of the Sampler until just snug. Replace Sample Screen and Plug.
- Using the chart, determine the correct amount of pressure to apply to the Sampler at the desired sampling depth.
- Turn the Pressurize/Vent Valve on the reel to Vent.
- Use a safety support line, such as the Model 103 Tag Line, to lower the Sampler to the proper sampling depth. (See 103 Data Sheet).
- Once at the desired sampling depth, turn the Pressurize/Vent Valve to Pressurize.
- Connect the air pump to the reel and pressurize the Discrete Interval Sampler as determined in step 6.
- Wait approximately 5–10 minutes for the Sampler to fill.
- Disconnect the air source and turn the Pressurize/Vent Valve on the reel to Vent to depressurize the line allowing the Piston to retract and close the Sample Release Valve. (ie. Sampler is still pressurized).
- Bring the Discrete Interval Sampler back to the surface.
- To retrieve the sample, remove the Sample Screen and Plug and hold the Discrete Interval Sampler upright over your sample container. Reconnect the air supply to the reel and turn the valve to Pressurize.
- Apply a minimum of 30 psi to open the Sample Release Valve and allow sample discharge. Increasing the pressure to 50 psi will increase sample discharge to about 250 mL/min.

Disassembly

1. Unscrew the Sample Screen Plug and remove the Sample Screen from the Sample Release Port.
2. Use a standard screwdriver to unscrew Sample Release Valve from the Piston Rod and remove from the Sample Release Port.
3. Unscrew the Sample Release Port from the Bottom Platen and unscrew Bottom Platen from the Sampler Body.
4. Unscrew the Sampler Body from the Pressure Chamber.
5. Unscrew the Top Platen from the Top Retainer. Or, if weights have been used, unscrew the Top Platen from the weight and unscrew the weight(s) from the Top Retainer.
6. Unscrew the Top Retainer from the Pressure Chamber.
7. Use the Allen Key to loosen the screws in the Pressure Retainer and slide the Pressure Retainer off the Piston Rod.
8. Holding the Piston Rod firmly, push the Piston out of the Pressure Chamber.

Decontamination

- Notes:**
1. Always follow your local guidelines and standard protocols.
 2. Replace worn o-rings. Never use Acetone on the o-rings

The Discrete Interval Sampler should be decontaminated after each sampling event.

1. Disassemble the Sampler.
2. Wash all Sampler parts in a phosphate-free soap.
3. Rinse all parts thoroughly with deionized water and dry.
4. Reassemble the Sampler.

Assembly

1. Ensure there are two V-009 O-rings on the Piston Rod and two V-121 O-rings on the Piston Head.
2. Slide the Piston Rod through the Pressure Chamber and with some force, pull the Piston Rod until you feel the two O-rings on the Piston seat inside the Chamber.
3. Ensure there is a V-124 O-ring on the Pressure Chamber.
4. Push the Piston Setting Tool into the Pressure Chamber and thread the Tool into the Pressure Chamber until it seats.
5. Slide the Pressure Retainer firmly against the Pressure Chamber, to cover the V-009 O-ring at the vent hole. Use the Allen Key to tighten the Pressure Retainer in place.
6. Remove the Piston Setting Tool.
7. Put the Piston Rod through the Sampler Body and screw the Sampler Body onto the Pressure Chamber.
8. Ensure there is a V-124 O-ring on the Top Retainer and thread it into the Pressure Chamber.

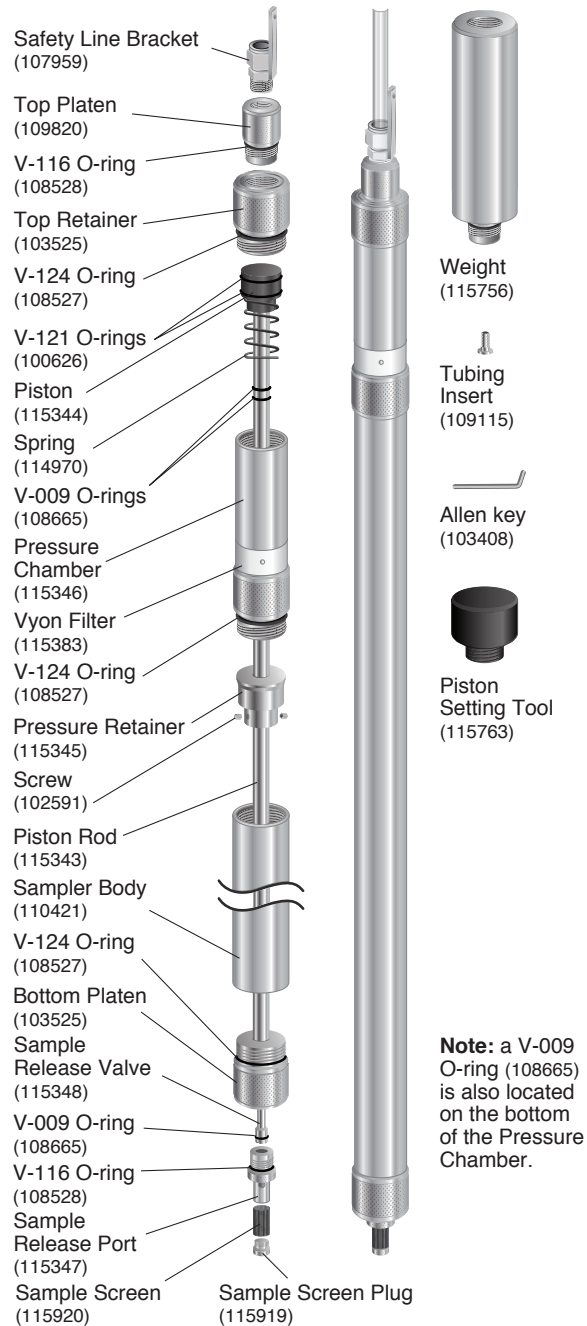

425-D Deep Sampling Discrete Interval Sampler (115342)

9. Ensure there is a V-116 O-ring on the Top Platen and thread it into the Top Retainer (see Page 1 if using weights).
10. Ensure there is a V-124 O-ring on the Bottom Platen and thread it into the Sampler Body.
11. Ensure there is a V-116 O-ring on the Sample Release Port and thread it into the Bottom Platen.
12. Ensure there is a V-009 O-ring on the Sample Release Valve and insert it through the Sample Release Port and thread it into the Piston Rod. Use a standard screwdriver to tighten it until just snug.
13. Place the Sample Screen over the Sample Release Port and screw the Sample Screen Plug into the Sample Release Port.

®Solinst is a registered trademark of Solinst Canada Ltd.